

Cylinder station HP 252

2x1 cylinder (bundle) single stage with automatic changeover - sequential version

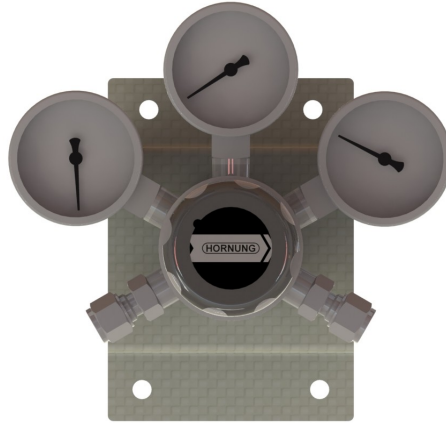

compression fittings optional

Special characteristics:

The HP 252 is a special version of a typical cylinder station with automatic changeover. It combines two pressure regulators which are placed in sequential position in one housing to save space.

Description:

The HP 252 is a single stage panel for central gas supply with automatic changeover. It serves the safe supply of pure and mixed gases from 2 single cylinders or cylinder bundles. The changeover sets in as soon as the pressure in the first side sinks below a predetermined level. This process is controlled by two installed regulators which are connected through one mutual housing.

The station is mounted on a stainless steel console and in standard version it consists of two pressure regulators and the in- and outlet gauges.

Application area:

Especially for gases with high requirements on purity up to 6.0, safety and density for which an uninterrupted supply overnight and weekends must be guaranteed.

The supply concept can be optimised by options such as contact gauges and gas alarm boxes (see segment 7).

Through our special cleaning system our pressure regulators are suitable for ECD – applications.

Technical details:

Body:	- stainless steel 1.4404 electro polished or - brass, nickel and matt chrome plated
Seat:	PCTFE
Diaphragm:	1.4435
Leakage rate:	10 ⁻⁸ mbar l/s He
Gas purity:	≤ 6.0
Max. inlet pressure:	300 bar
Outlet pressure ranges:	10 – 12 bar
Cv value:	0.06
Operating temp.:	-20°C to +70°C
Gauges:	inlet gauge outlet gauge
Dimensions (WxHxD):	90x125x205
Weight:	2200g
Connections:	NPT ¼" f

Hornung Quality standard

The company Hornung is certified to
ISO 9001:2008 and ISO 14001:2009.

All single parts are manufactured, assembled
and tested by in-house production.

The finished parts are therefore under all criteria
of German quality control with 100% final
inspection.

Hornung GmbH
Rathenaustraße 55, 63263 Neu-Isenburg

Phone: +49 6102 7883-70
Fax: +49 6102 7883-40

www.hornung.org
info@hornung.org

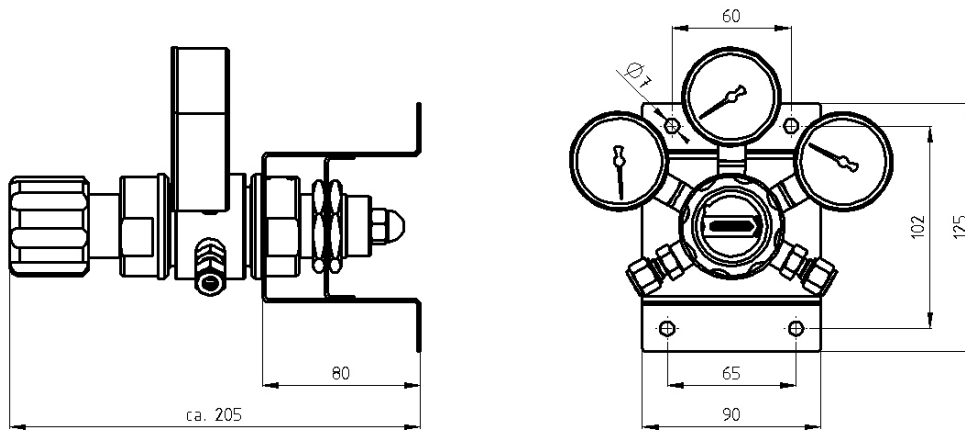

Flow diagram:

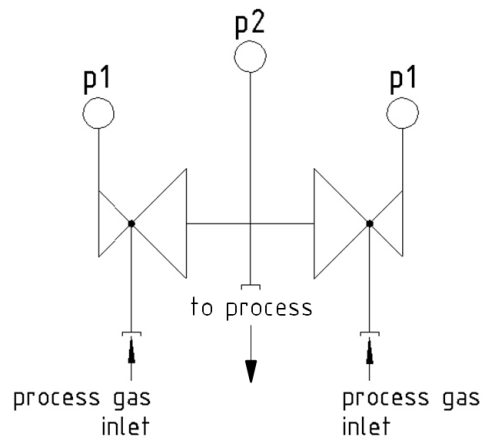

Accessories:

See total catalogue segment

- 7. Pigtail 200bar
- Pigtail 300bar
- Connecting hose 200bar
- Connecting hose 300bar

Gauges, compression fittings, cylinder holders and accessories.
Gas cylinder cabinets and safety equipment.

Scope of delivery:

Cylinder station with inlet and outlet gauges, mounted on a stainless steel wall bracket.

Compression fittings are not included.

Ordering information:

Material:

- 1 = stainless steel
- 2 = brass

Inlet pressure (p1):

- 1 = 200 bar
- 2 = 300 bar

Outlet pressure (p2):

- 1 = 10-12 bar

Gauges:

- 1 = standard gauge
- 2 = contact gauge Ex

HP252-	2	1	1	1	Gas
Type	Mat.	p1	p2	Gauge	Gas type